

DRUM PUMPS & ACCESSORIES

Before ordering any pump, establishing compatibility with the MSDS of the fluid used in application is a must!
Bond/ground cables on page B116 are required when pumping flammable or combustible liquids.

STAINLESS STEEL PUMPS

- Efficient transfer of liquids from 25 or 45-gallon drums
- Stainless/Teflon® pump handles most liquids, including aggressive acids and corrosives
- 316 stainless steel construction with Teflon® piston, shaft and seal
- Stainless/polyethylene pump withstands phosphoric acids and alkalis
- Chrome plated steel pump with polyethylene components handles mildly corrosive water based fluids, solvents and light oils
- All pumps fit standard 2" bung and deliver 8 oz. per stroke
- 25" L with a 7" L x 1/2" O.D. spout and 22" L suction tube
- Weight: 3 lbs.

Model No.	Pump Construction
DA531	316 SS/Teflon®
DA530	304 SS/Polyethylene
DA527	Chrome Steel/Polyethylene

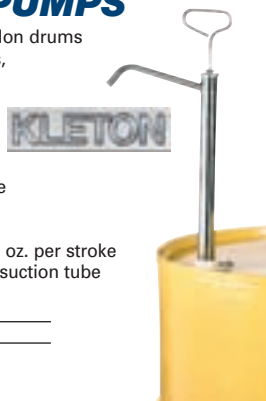

STAINLESS STEEL LIFT STYLE PUMPS

- Excellent for the fast transfer of acids and corrosives
- Delivers 22 oz. per stroke
- Model DA529 is constructed of 304 stainless steel with Teflon® seal
- Model DB845 is constructed of 316 stainless steel with Teflon® seal
- Fits standard 2" bung for 45 gallon drums
- 45" L with a 7" L x 3/4" O.D. spout
- Weight: 6 lbs.

Model No. DA529

Model No. DB845



ROTARY PUMPS

- Efficiently pumps 5 gallons per 80 handle revolutions
- Body and blades are constructed of rugged cast iron
- Model DA528 handles medium viscosity petroleum based products such as light oils
- Model DA536 with non-sparking nozzle is ideal for transferring gasoline and diesel fuel
- Both models pump in either direction, out the nozzle or in the nozzle, when used with partially submerged hose and cranked in opposite direction
- 1 1/4" x 40" steel suction tube, 1" discharge tube, 2" bung adaptor
- Weight: 17 lbs.

Model No. DA528

Model No. DA536



TRANSFER PUMP

- Non-corrosive, double action piston pump is designed to handle most petroleum products, solvents and industrial chemicals with viscosities up to 2000 SSU
- Discharges 1 quart per stroke with a suction lift to 15'
- Handle can be mounted above or below pump
- Tamper proof feature enables padlocking to protect against unauthorized use
- Thermoplastic constructed pump has a polyester glass reinforced body, Vitor® "O" ring and cork-nitrile gasket
- All internal metal parts in contact with liquid are 316 stainless steel
- Includes 8' PVC black vinyl discharge hose, 2-piece 1" x 34" L polyester suction tube, polyester discharge spout and 2" bung adaptor
- Weight: 11 lbs.

Model No. DA526



HORIZONTAL DRUM GAUGE

- Reads instantly and accurately the amount of liquid in a 45-gallon drum
- Mounts through 2" bung hole; seals tight and won't leak
- Reads in 5-gallon intervals
- Weight: 2 lbs.

Model No. DA067



GRADUATED DRUM GAUGES

- The solution to visually gauging contents of horizontal drums
- Excellent for most oils, solvents and chemicals
- Combination gauge and faucet permits uninterrupted draining of drum contents with gauge in place
- Mounts through 3/4" bung hole
- Constructed of heavy gauge glass in plated steel body with Buna-N seals
- Weight: 3 lbs.

Model No.	Description
DA064	Gauge only
DA065	Gauge with faucet*

*Zinc die cast faucet FM approved for viscous liquids only; no flame arrestor.



DRUM FILL GAUGE

- Provides a low cost solution to over-filling drums
- When drum is almost full, indicator "Pops-Up" to warn you
- Fits in standard 3/4" bung opening, and is 5"L
- Bright red and yellow moulded polyethylene
- FM approved
- Weight: 0.2 oz.

Model No. DA066



SAFETY PUMPS

- FM Approved for handling flammables
- Comes complete with internal flame arrestor, steel bung adaptor to aid static grounding, and heavy duty bonding wires to remove hazardous static charge
- Steel pickup tube with internal screen keeps debris out of pump
- Constructed of highly polished carbon steel with Teflon® piston, packing and gasket for exceptional chemical and solvent resistance
- Pumps 8 oz. per stroke, designed to fit 45 gallon drums
- Also available in stainless steel for corrosive flammable liquids
- Weight: 5 lbs.

Model No. DA513 Carbon Steel

Model No. DB831 Stainless Steel

VERTICAL DRUM GAUGES

- Accurate "At-A-Glance" monitoring
- Easy-to-read gauge is calibrated in gallons, litres and percentage remaining in drum
- Monitors liquid level in vertical 45-gallon drums
- Heavy steel and plastic construction with leak proof neoprene gaskets
- Resistant to oil and many chemicals
- Available for 3/4" or 2" NPT bung opening
- Weight: 1 lbs.

Model No.	Bung Size"
DA069	3/4
DA068	2

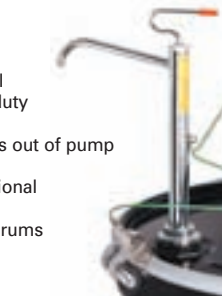

ENVIRO-WEDGE™

- Increases the amount of product pumped out of 25-45 gallon drums
- Reduces the amount of expensive product left in drum while also allowing for easier drum reconditioning and disposal
- 100% recycled, rugged polyethylene construction
- Weight: 1.5 lbs.

Model No. DA660



DRUM HANDLERS

DRUM ROCKERS

- Safe method of upending up to 45 gallon drums for moving, draining or storing
- No lifting, straining, or danger of drum tipping backwards
- Load drum into the draining position in seconds
- Constructed of all welded heavy gauge steel tubing
- Handle is removable
- Swivel casters are 2 1/2" polyolefin, wheels are 3" polyolefin
- Capacity: 1000 lbs.

KLETON



Model No.	Description	Wt. lbs.
DA592	Two swivel casters, two 3" wheels	38
DA591	Four 3" wheels	35
DA589	Frame only, no wheels	31

LOW PROFILE DRUM TRUCK

- Ideal for moving full, open top 45-gallon drums without spilling contents
- With a low-level frame, only 1" from the ground, this truck allows for easy loading of drums up to 1000 lbs.
- Hinged handle moves forward and backward for easy pushing or pulling
- All-welded steel construction with 8" x 2" rubber wheels and 4" resilient non-marking swivel caster for smooth movement and easy manoeuvrability
- Weight: 35 lbs.

Model No. DA579

KLETON



MOBILE DRUM KARRIERS

- Transports, rotates, tilts and drains fully loaded drums up to 800 lbs.
- Easy to operate
- Drum can be raised to a floor clearance of 5 1/8" to 11 1/2", automatically sets lock which prevents unintentional lowering
- Tilt lock on each side of unit keeps drum in desired position
- All-welded steel construction; 8" polyolefin wheels and 4" swivel caster for easy manoeuvrability
- Weight: 106 lbs.

MORSE

Model No.	Drum Size
DA189	45-gallon steel; 22 1/2" dia.
DA190	45-gallon plastic and steel; 22 1/2" - 24" dia., 34" - 36" H
DA191	25 and 45 gallon steel; 18" - 22 1/2" dia.
DA192	21" - 23" dia. fibre and steel
DA193	25 and 45 gallon fibre and steel; 18 1/2" - 22 1/2" dia.

STEEL DRUM DOLLIES

- Built to withstand constant use
- All-welded frame
- 24" inside diameter handles
- 45-gallon drums



DA602



DA583

KLETON

Model No.	Frame Style	Approx. Height"	Wheel Type	Cap. lbs.	Wt. lbs.
DA602	Round	5 1/2	3" Polyolefin	750	22
DA583	X-Frame	5 1/2	3" Polyolefin	750	22

POLYETHYLENE DOLLY

This 500 lbs. capacity, structural foam polyethylene dolly won't dent, corrode or rust. Solid bottom construction with 2" lip contains small spills. Handles 45 gallon drums. Overall dimensions: 24 3/8" diameter x 7 1/8" H. Rolls on five 3" hard rubber casters. Weight: 17 lbs. Colour: Black.

Model No. NA714



Rubbermaid
Commercial Products

LIL'DOLLY™ PAIL DOLLY

- Designed for use in hospitals, food processing plants, manufacturing locations, hotels, restaurants
- anywhere 5, 6 & 15 gallon pails are used
- 5 dual wheel swivel stem casters
- Inside diameter: 11"
- Capacity: 75 lbs.
- Weight: 2 lbs.
- Colour: Beige

Model No. MD527



DRIP CATCHER DOLLY

This oversize drum dolly catches drips in the pan, keeps area around drum clean. Handles standard 45-gallon drums and larger containers up to 27" in diameter. 2" lip contains drips, holds absorbent sock (included).

Overall dimensions: 31 1/2" diameter x 5 3/4" H 3 3/4" x 1/4" rubber casters. Capacity: 1000 lbs. Weight: 26 lbs. Colour: Safety yellow.

Model No. DA600



VALLEYCRAFT
ALL IN A DAY'S WORK

DRUM HANDLERS & RACKS

DRUM STACKING RACK

- Designed to give maximum flexibility
- Provides 4-way fork truck or pallet truck entry allowing for easy drum relocation
- Each rack holds two 45-gallon drums and is stackable up to 4 high
- Overall dimensions: 54 1/2" x 29 1/2"
- Wt.: 38 lbs.
- Shipped knocked down

Model No. DA537

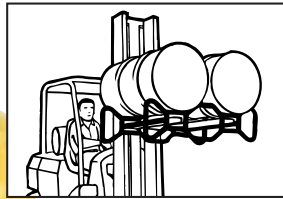

KLETON

DA537 (qty 2)
shown for product
illustration

BARREL HAWK™ RAPTOR DRUM HANDLER

- Reduce the risk of back and muscle injury
- Jaw clamp attaches securely to rimmed steel drums while hand operated hydraulic pump lifts 45-gallon drum up to 19" off the floor
- Easy to lift drum from any pallet, skid or containment basin location because handler legs fit right into corner
- Rolls smoothly on one rear swivel caster (w/brake) and two front fixed wheels
- Designed for use on steel drums only
- Overall dimensions: 49 1/2" W (Outside) 43" W (Inside) x 40" D x 60 1/2" H
- Capacity: 800 lbs.
- Wt. 232 lbs.
- Strapping not included

Model No. DA809

BARREL HAWK
Raptor



MORSE

MORStop™ Tilt Brake



HYDRA-LIFT DRUM HANDLERS

- A safe way to lift, move, tilt and drain 45-gallon drums
- Manual control; pump-handle lifts drum, maximum extension is 45 strokes
- Hand crank controls tilt angle of drum up to 360° in either direction for controlled pouring of contents, chain wheel controls tilt for 72" and higher lift models
- 800 lbs. full drum capacity; 500 lbs. half-full capacity
- Rugged, heavy-duty welded frame; 8" polyolefin wheels and 4" swivel casters; screw-down floor lock
- Power lift and power tilt with a choice of motors is optional
- Shipped partially disassembled
- Powered models eliminate the manual effort of drum raising and tilting; increases productivity and safety
- Optional MORStop™ tilt brake holds drum tilt position constant even when tension from the pull chain is removed

MANUAL LIFT - For the 60" dispensing height unit, the tilt function is controlled by a hand crank. The 72" and 96" tilt control is with a chain wheel.

POWER LIFT - Moving valve handle to up, down or hold position controls drum height; 25 second lifting time.

POWER LIFT & TILT - One valve controls lifting, another controls tilt angle. Ideal when hand crank or chain drop is out of reach.

Dispensing Height"	H"	L"	O.D."	I.D."
60	55	60	44	37
72	55	60	44	37
84	61	72 1/2	49	42
96	69	76 1/2	50	43

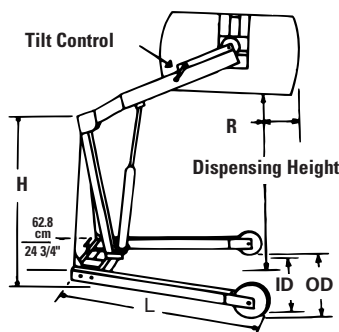

Dispensing Height		Description	
60"	72"	96"	
Model No.	Model No.	Model No.	
DA138	DA143	DA153	Manual Hydra lift and tilt
DA139	DA144	DA154	Hydra lift c/w air power lift and power tilt
DA140	DA145	DA155	Hydra lift c/w 12V DC power lift and power tilt**
DA141	DA146	DA156	Hydra lift c/w air power lift and manual tilt*
DA142	DA147	DA157	Hydra lift c/w 12V DC power lift and manual tilt**

OPTION

DC077 MORStop™ Tilt Brake Option

* Filter, regulator, lubricator and valve not included ** Battery and charger included