

SPILL CONTROL

THE POLY-RACK™ SYSTEM

The most efficient dispensing/storage system!

POLY-RACKER™

- One-piece polyethylene rack that holds two 45-gallon drums
- 100 plus gallon containment sump
- Deep dispensing well easily holds 5-gallon pails
- Both sides of the unit have a drain plug
- Entire unit can be transported by forklift
- Rated to hold up to 3000 lbs.

POLY-STACKER™

- Holds two 45-gallon drums
- Can be quickly stacked with a forklift
- Any spills from the second and third level falls into the dispensing well for containment and easy cleanup

POLY-SHELF™

- It easily attaches to *Poly-Stacker™*
- Allows simultaneous dispensing from all drums
- A hole in the bottom of the *Poly-Shelf™* drains into the dispensing well in the *Poly-Racker™*

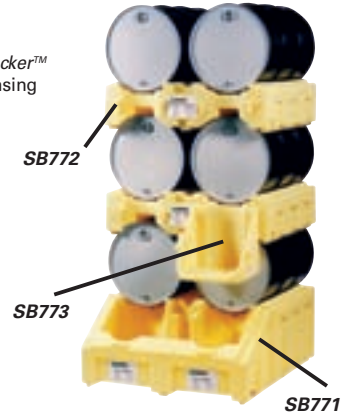

Model No.	Mfg. No.	Description	Max Capacity lbs.	Dimensions L" x W" x H"	Wt. lbs.
SB771	6000-YE	<i>Poly-Racker™</i>	3000	49 x 52 1/2 x 22 1/2	120
SB772	6002-YE	<i>Poly-Stacker™</i>	2400	49 x 41 x 13	56
SR466	6006-YE	Single <i>Poly-Racker™</i>	1600	31 x 53 x 32	95
SR467	6007-YE	Single <i>Poly-Stacker™</i>	800	31 x 40 1/2 x 20	50
SB773*	6003-YE	<i>Poly-Shelf™</i>	10	17 x 22 x 17 1/2	10

*Use only with *Poly-Racker™* or *Poly-Stacker™*

POLY-SAFETYPACK®

Safe, secure two-drum storage!

- Tough, indoor or outdoor performer protects two 45-gallon drums
- Hinged, gull-wing covers
- 100% polyethylene; chemical and weather resistant
- Security lock included
- Removable polyethylene grating 48" x 24" x 1 3/4"
- Translucent yellow sidewalls allow visual leak detection
- Easily handles by forklift or pallet jack from two sides
- For easier mobility, use the *Poly-Safetypack®* caster frame assembly **SE565**
- 135 US gallon sump capacity
- **Exterior Dimensions:** 60 1/4" L x 36 1/2" W x 45 3/4" H
- **Interior Dimensions:** 52" L x 26 1/2" W x 37" H



Model	Mfg No.	Description	Wt. lbs.
SB757	2038-YE	<i>Poly-Safetypack®</i>	115
SR415	2038-YE-D	<i>Poly-Safetypack®</i> W/Drain	115
SE565	2200-BK	<i>Poly-Safetypack®</i> Caster Frame	37

POLY-OVERPACK® 95 SALVAGE DRUM

Lightweight polyethylene Overpack can contain a broad range of hazardous chemicals including acids and corrosives!

- Damaged and deformed drums can be overpacked easily
- Twist on lid with a closed cell polyethylene gasket can be closed securely and easily by using any long object, like a two-by-four
- Accepts all 45-gallon drums
- Meets performance-oriented packaging requirements of U.S. DOT and UN regulations as well as Group 1 packaging standards and salvage drum regulations
- Moulded area allows for easy gripping and pick-up by material handling equipment
- **Exterior dimensions:** 31 3/4" top dia. x 26" bottom dia. x 41 1/2" H
- **Interior dimensions:** 27" top dia. x 24 3/4" bottom dia. x 37" H
- 95 US gallon sump capacity

Model No.	Description	Wt. lbs.
SB756	<i>Poly Overpack® 95</i>	53
DA224	Drum Lifter	21



POLY-OVERPACK® 20 & 30

- Versatile units that can contain solids and sludges with security
- Nestable for compact shipment
- 1/2-turn lid for easy opening and closing
- Built-in shoulder for easy handling
- UN rated salvage drums

POLY-OVERPACK® 20

- Accepts bottles, cans, and 5-gallon pails
- **Exterior dimensions:** 23" top dia. x 18" bottom dia. x 19" H
- **Interior dimensions:** 21 1/2" top dia. x 17" bottom dia. x 17 1/2" H
- 20 US-gallon sump capacity

POLY-OVERPACK® 30

- Unit can contain up to 16 US gallon drums
- **Exterior dimensions:** 23" top dia. x 18" bottom dia. x 30" H
- **Interior dimensions:** 21 1/2" top dia. x 17" bottom dia. x 28 1/2" H
- 30 US-gallon sump capacity

Model No.	Description	Wt. lbs.
SAG189	<i>Poly-Overpack® 20</i>	10
SAH551	<i>Poly-Overpack® 30</i>	13



POLY-DOLLY®

The multi-functional, two-wheel dispensing station!

- Transports 45-gallon drums with ease
- Tilts to become an efficient self-dispensing station
- Acts as its own secondary containment unit
- Integrally moulded handles for extra strength
- Double looped strap for easy loading
- Accessible to forklift from the rear
- Raised ribbed dispensing well
- Drain plug for removal of contents from sump
- Available as an *All Terrain Dolly*
- **Dimensions:** 69" L x 32 1/2" W x 26 1/2" H
- 80 US gallon sump capacity
- 600-lbs. load bearing capacity

Order No.	Mfg. No.	Description	Wt. lbs.
SB769	5300-YE	<i>Poly-Dolly®</i>	92
SB770	5300-YE-A	<i>Poly-Dolly®</i> ATD*	96
SR444	5312-YE-A	<i>Poly-Dolly®</i> Cover	-

*All Terrain Dolly with heavy-duty pneumatic rubber wheels.



SPILL SCOOTER™

- Polyethylene construction
- Contains incidental spills and drips
- Spout included for easy draining
- Fits drums up to 45 gallons
- Optional metal T-handle available separately, 36 5/8" long
- **Dimensions:** 34 1/2" diameter x 9" high
- 500-lbs. load bearing capacity
- 10 US gallon capacity

Model No.	Description	Wt. lbs.
SB767	<i>Spill Scooter™</i>	22.5
SC554	T-handle	4



22351E



B111

DRUM HANDLERS & RACKS

DRUM STACKING RACK

- Designed to give maximum flexibility
- Provides 4-way fork truck or pallet truck entry allowing for easy drum relocation
- Each rack holds two 45-gallon drums and is stackable up to 4 high
- Overall dimensions: 54 1/2" x 29 1/2"
- Wt.: 38 lbs.
- Shipped knocked down

Model No. DA537

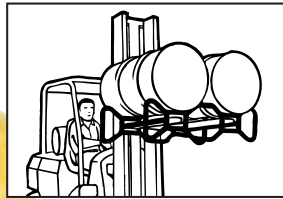

KLETON

DA537 (qty 2)
shown for product
illustration

BARREL HAWK™ RAPTOR DRUM HANDLER

- Reduce the risk of back and muscle injury
- Jaw clamp attaches securely to rimmed steel drums while hand operated hydraulic pump lifts 45-gallon drum up to 19" off the floor
- Easy to lift drum from any pallet, skid or containment basin location because handler legs fit right into corner
- Rolls smoothly on one rear swivel caster (w/brake) and two front fixed wheels
- Designed for use on steel drums only
- Overall dimensions: 49 1/2" W (Outside) 43" W (Inside) x 40" D x 60 1/2" H
- Capacity: 800 lbs.
- Wt. 232 lbs.
- Strapping not included

Model No. DA809

BARREL HAWK
Raptor



MORSE

MORStop™ Tilt Brake



HYDRA-LIFT DRUM HANDLERS

- A safe way to lift, move, tilt and drain 45-gallon drums
- Manual control; pump-handle lifts drum, maximum extension is 45 strokes
- Hand crank controls tilt angle of drum up to 360° in either direction for controlled pouring of contents, chain wheel controls tilt for 72" and higher lift models
- 800 lbs. full drum capacity; 500 lbs. half-full capacity
- Rugged, heavy-duty welded frame; 8" polyolefin wheels and 4" swivel casters; screw-down floor lock
- Power lift and power tilt with a choice of motors is optional
- Shipped partially disassembled
- Powered models eliminate the manual effort of drum raising and tilting; increases productivity and safety
- Optional MORStop™ tilt brake holds drum tilt position constant even when tension from the pull chain is removed

MANUAL LIFT - For the 60" dispensing height unit, the tilt function is controlled by a hand crank. The 72" and 96" tilt control is with a chain wheel.

POWER LIFT - Moving valve handle to up, down or hold position controls drum height; 25 second lifting time.

POWER LIFT & TILT - One valve controls lifting, another controls tilt angle. Ideal when hand crank or chain drop is out of reach.

Dispensing Height"	H"	L"	O.D."	I.D."
60	55	60	44	37
72	55	60	44	37
84	61	72 1/2	49	42
96	69	76 1/2	50	43

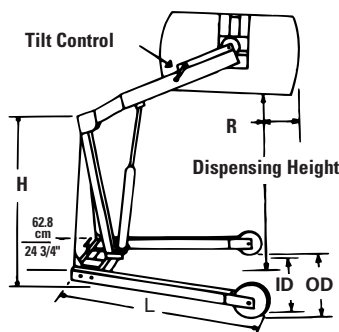

Dispensing Height		Description	
60"	72"	96"	
Model No.	Model No.	Model No.	
DA138	DA143	DA153	Manual Hydra lift and tilt
DA139	DA144	DA154	Hydra lift c/w air power lift and power tilt
DA140	DA145	DA155	Hydra lift c/w 12V DC power lift and power tilt**
DA141	DA146	DA156	Hydra lift c/w air power lift and manual tilt*
DA142	DA147	DA157	Hydra lift c/w 12V DC power lift and manual tilt**

OPTION

DC077 MORStop™ Tilt Brake Option

* Filter, regulator, lubricator and valve not included ** Battery and charger included